



evolution[®]

Operation & Maintenance Guide

Helping you to take care of
your new Evolution Products



Contents

Introduction	1
Cleaning	2
Maintenance	3
Condensation	4-5
Operating instructions windows & doors	6-9
Care Guide (painted frames, Traditional hardware maintenance)	10-12
Bi-fold Maintenance	13
Operating Instructions	14-15
Quality of Vision - Glass	16-20
Protection of Windows & Glass	21



EVOLUTION PRODUCT CARE AND MAINTENANCE

storme the english door flush
company

Our structurally sound, technically advanced windows, doors and orangeries will provide you with many years of trouble-free, low maintenance living.

We want your Evolution products to maintain their appearance and durability for many years to come.

Evolution products are designed to be low-maintenance and long lasting. These simple maintenance and operating guidelines will ensure you prolong the life of your Evolution products, keeping them in excellent condition and looking their very best.



Introduction

Cleaning

Window & Door Frames

Wash frames with a soap and water solution at least:

- Every three months in areas of heavy vehicular traffic.
- Every six months in rural areas.

Clean with a non-abrasive proprietary cleaner, suitable for plastics using a soft cloth.

Glass

- External dirt and grime should be removed from the glass surface using a solution of soap and water.
- Any household glass cleaner may be used with a soft cloth.

Note: Avoid all solvent based or abrasive cleaners. Take care not to disturb silicone pointing sealants.



Leaded Glass

- Take care when cleaning leaded glass as excessive pressure can dislodge the lead from the glass surface.
- Warm soapy water moderately applied with a cloth will prove an adequate cleaning method.

Maintenance



PVCu Frames

PVCu requires no maintenance other than cleaning. In the event of damage please contact your local Evolution authorised installer. Periodically and where accessible, clear drainage holes which can be seen when you open your windows and doors.



Gaskets

If the gaskets are broken or damaged and draughts are felt around the unit, ensure prompt replacement by contacting your installer.

Hardware Fittings

An oil or light grease applied to the mechanisms and stays once a year will enhance corrosion resistance.



Condensation



Causes of Condensation

Condensation is moisture in the air turned into water.

The warmer the air is, the more moisture it can hold, when its limit is reached and the warm air makes contact with a cold, non-absorbant surface, it becomes chilled and sheds the excess moisture in water droplets, usually seen on glass surfaces.

Living Room

Allow the rooms warmth to reach windows by positioning the curtains slightly away from the windows



Bathroom

- To stop moisture from travelling around the house, keep the door closed during and after bathing.
- Whilst bathing it is advisable to open windows slightly to aid ventilation.

Bedroom

The prime cause for condensation in bedrooms is not allowing for the night time drop in outside temperatures.

- Extend the central heating programme or other heating system accordingly.
- Ventilate by opening the windows at least once a day to allow air-exchanges.

Kitchen

- Close door ways into the remainder of the house and keep a window open.
- Extractor fans can help.

Condensation

Outdoor Condensation

Condensation forms on the outdoor surface of glass when its temperature drops below the outdoor dew point temperature.



Evolution windows are manufactured using thermally efficient glass. The glass keeps heat inside the rooms of your house and reflects heat from radiators and fires back into the room.

As a result, the outer pane of glass does not get warmed by heat escaping from inside the building through the glass and remains cooler in comparison to much less thermally efficient windows.



It is possible that external condensation will appear on the same windows but not on others, due to the position of windows in the house.

If condensation appears externally on your windows, this is in no way a defect of the unit. It must be seen as a positive indication that your windows are thermally efficient and are reducing heat loss.

*We cannot guarantee against the incidence of condensation.

Operating Instructions

Opening the windows

Friction hinges keep this window in the desired position once open. The window also has a 'night vent' position. This allows the window to be slightly open, but still locked.

Operating Instructions

- Turn the key or depress the button to unlock the handle (if applicable)
- Rotate the handle to disengage locking mechanism and open the window by pushing it outward.
- The locking keeps have two slots, the first on which when engaged provides the closed position and the second provides the 'night vent' position.



Residential Doors

Doors are fitted with lever/lever handles as standard. The option to have a lever pad or handle-less entry is available.

Operating Instructions

- Close the door and the latch engages
- Lift handle until you feel resistance, then continue action to overcome the resistance to engage the lock mechanism. Once engaged, release the handle.
- Turn the key to fully lock (note: if key will not turn, re-lift handle or pad to maximum position and then turn the key.)

To unlock

- Turn the key to unlock
- Push handle down to disengage the lock mechanism and open the door.



Operating Instructions

Operating Instructions for Lever/Pad

- Close the door and the latch engages.
Note. At this point entry from outside of the property can only be gained with use of the key to release the latch.
- Lift the Pad handle until you feel resistance, then continue the action to overcome the resistance to engage the lock mechanism. Once engaged, release the handle.
- Turn the key to fully lock (note: if key will not turn, the locks have probably not fully engaged so, lift the handle again to engage the locks fully).

To unlock

- Turn the key to unlock.
- Push the pad handle down to disengage the lock mechanism, turn the key again to release the latch and open the door.

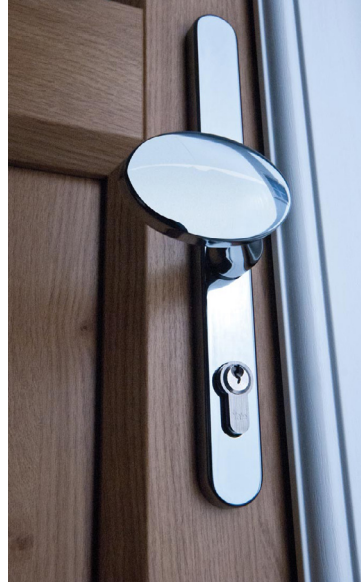

Operating Instructions

Standard Friction Hinge

- Adjustment is available on certain hinges by means of a screw located within the plastic shoe.
- The friction shoe should be adjusted to give the required degree of resistance.
- Anti-clockwise decreases the resistance, clockwise increases the resistance.

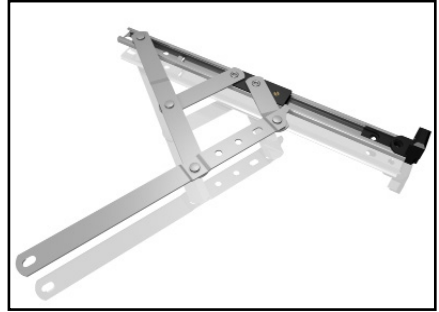

Egress Easy Clean Hinge

To move the sash into the easy clean position:

- Open the window approx. 10"/12" (250/300mm)
- Locate and slide the coloured guide component into the front location area. The coloured guides are to be located at the top and bottom of the window.



NOTE: Both upper and lower hinges need locating.

- Using the window handle, continue to open the window to its full extent. This will activate the hinge guide and allow for access cleaning.
- When you have finished cleaning your window, simply close the vent fully using the handle and then re-open the vent fully to relocate the coloured guides into their primary position.

Side Hung Restrictor

When moving the window grasp frame, do NOT put force on the glass.

- To fully open the window, firstly draw the window slightly towards you then press the lever and push the window open to release the restrictor mechanism.
- To reset the restrictor, press the lever, pull the window in and the mechanism will relocate.

Operating Instructions

Egress Easy Clean Hinge Operating Instructions

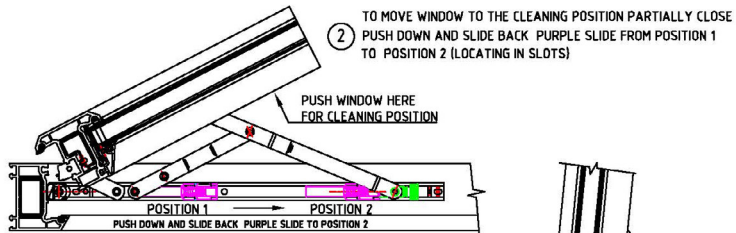
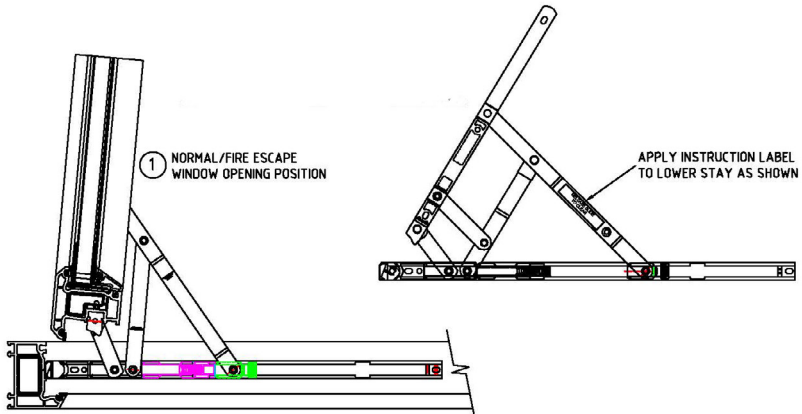

③ USING THE HANDLE - OPEN THE WINDOW TO THE CLEANING POSITION

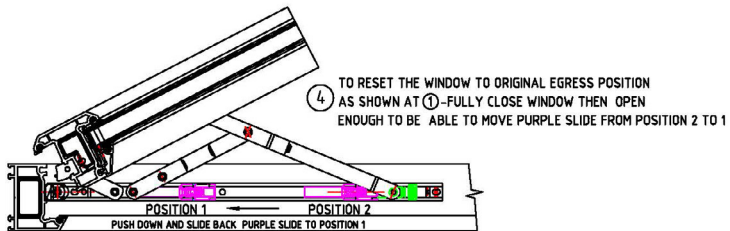
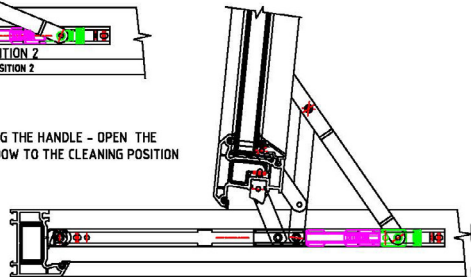

IT IS THE RESPONSIBILITY OF THE WINDOW MANUFACTURER TO ENSURE THAT THE FINISHED WINDOWS MEET ANY REQUIRED SAFETY AND PERFORMANCE SPECIFICATIONS

Care Guide

Painted Frames -

Important information to be read prior to installation

- Do not remove any protective film until the window/door installation is complete.
- Ensure the painted frame does not come into contact with any harmful building materials for example: sand or cement.
- Window and door frames should only be cleaned with luke warm water with a mild detergent. Detergents must not contain solvents or abrasives.
- Any traces left on the glass after removing stickers can also be cleaned using luke warm water with mild detergent, do not use any window scrapers or sharp objects that may scratch the glass.
- For added protection an automotive wax can be used (non abrasive) this is particularly recommended in coastal areas to resist against salt spray and further protect from the external elements.



Care Guide

Wrought Iron, Black & Pewter Furniture

Iron in any form whether Cast or Malleable is susceptible to rusting.

During our finishing process we endeavour to cover all areas of Antique ironmongery by a two coat paint process which is then cured by stove drying.

When two areas of components come into contact with each other, and abrasive action is enacted, and at some point the painting process is lost by this contact.

Please ensure the article is periodically wiped over with a lightly oiled cloth, and where obvious abrasive areas of moving parts are visible especially external items, a regular light oiling is recommended (Coastal areas may require this maintenance process more frequently).



Ironmongery fitted externally will require greater attention due to increased exposure to atmospheric conditions.

If this process has not been done the warranty will be void.

By adopting these simple precautions you will prolong the products life and enhance the beauty of your home.

Traditional Window Fittings Ironmongery are made in the UK using the same methods for the past 150 years.

Care Guide

Brass & Chrome Brass Furniture

Polished Chrome

Regular cleaning with warm soapy water will help to maintain the appearance, but if required a proprietary brand of chrome polish can be used (e.g Autosol)

Lacquered Polished Brass

Our products are protected by the most advanced lacquer available and under normal circumstances should give many years of service.

They should be cleaned with a soft cloth moistened with warm soapy water or alternatively wiped over with a soft cloth with beeswax polish.

UNDER NO CIRCUMSTANCES USE ANY FORM OF METAL CLEANER OR AEROSOL SPRAYS.



However, after a period of time the lacquer coating especially on external fittings, can suffer a possible breakdown, especially in coastal areas where the salt air can attack the lacquer more than normal.

Therefore, the life of the lacquer is beyond the manufacturers control and cannot be guaranteed.

Protect the uPVC area by masking off an area around each piece of brass work or removing the item to be refurbished.



Bi-Fold Maintenance

Bi-Fold Doors

Your Bi-Fold Door system contains mechanical moving parts that will need to be lubricated bi-annually. These include: hinges, multipoint lock and handles. Lubricate using a light oil or spray oil and wipe away any excess with a non-abrasive cloth once you have finished.

The running system in your Bi-Fold Door is maintenance free.

DO NOT USE solvent based cleaning products on the gaskets.

It is recommended that you use a silicon spray to the gaskets annually.

- Weathering gaskets - use a light soapy solution and a non-abrasive cloth.
- Tracks - use a small brush or vacuum any dirt from the track

During high winds, ensure that the doors are kept closed to avoid structural damage.



Operating Instructions



Bi-Fold Doors - Opening

To ensure years of trouble free use from your bi-fold doors it is recommended that you read and fully understand the operating instructions as follows:

- Insert key into the lead door and turn through 360 to release the deadbolt into the multipoint lock.

Operate the door handle in a downward motion to release the multipoint locking system latch. Open the door fully through 180 and ensure that the magnetic door stays are holding the door fully open.

(This will help the doors glide more easily)

- Release the shoot bolts on the slave doors by turning the shoot bolt lever through 90 and level in this position.

Push the doors away from you (if the doors open out if the room) or pull the doors towards you (if the doors open into the room) to start the folding operation.

- At the hinge side of the lead door, guide the doors along the track system until they are fully open.

Repeat steps 2 and 3 as necessary if you have more than 3 doors in one direction.



Operating Instructions



Bi-Fold Doors - Closing

- Guide the lead door at the hinge side along the track.

Do not drag the lead door handle to drag the doors along the track as it will cause the doors to operate in accordion type motion and restrict the effectiveness of running gear.

Keep the lead door located on the magnetic door stays.

- Use the 'D' handle (if fitted) to pull the doors closed.

Turn the shoot bolt lever in a downward motion through 90 to locate the shoot bolt in the track. Do not use the shoot bolt lever to pull the door closed.

- Using the lead door handle, pull the door closed until it latches, then lift the handle upwards to engage the multi-point lock and turn the key clockwise through 360 to engage the deadbolt in the multi-point lock.

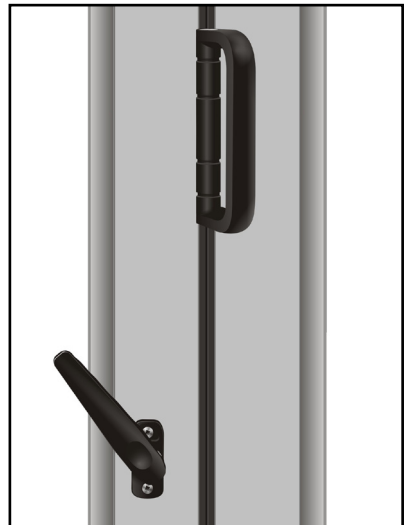

Quality of Vision - Glass



The quality of glass used in the production of double glazed sealed units has improved significantly over recent years.

However, due to the manufacturing process of both the glass and the sealed unit, there may be instances in certain lighting conditions of small scratches, blemishes or imperfections being apparent.

The information detailed is designed to help our customers and consumers understand the tolerances allowed under the standards we and the rest of our industry work to.

Evolution Manufacturing Ltd implements these standards as part of our product specification and quality control.

evolution[®]

Insulating Glass Units (IGUs) commonly known as “Double glazing” provide a high standard of vision.

The following is a guide to the quality that can be expected. Glass used in the manufacture of IGUs is similar to that used traditionally for single glass and will, therefore, have a similar level of visual quality.

Viewing IGUs for scratches on the outer faces of the panes must be carried out before any rendering, plastering or other works adjacent to the glazing takes place, and as early as reasonably practicable following installation.

Quality of Vision - Glass

How to do a professional check

Stand in the room no less than 2 metres away from the IGU and look directly through them.

- For toughened, laminated or coated glasses, stand no less than 3 meters away.
- Do so in natural daylight, but not directly towards the sun and with no visible moisture on the surface of the glass.
- Where it is not possible to stand at the right distance then stand as far away as you can from the IGU.
- Exclude 50mm wide band around edge of the glass from the check.
- Glass must be viewed at 90 to the window.

What to expect when viewed as described

Flat transparent glass, including laminated or toughened (tempered) or coated glass is acceptable if the following are neither obtrusive nor bunched:

- Bubbles or blisters
- Fine scratches not more than 25mm long
- Minute particles.

The obtrusiveness of blemishes is judged by looking through the glass, not at it, under natural light. It must be understood that the glass used in double glazing is a processed glass, and so as a consequence, blemishes are to be expected. Insulating glass units with optical defects such as smears, finger prints or other dirt on the cavity faces of the glass, or extraneous material in the cavity are unacceptable, except in some cases where small particles of desiccant can be seen.



Quality of Vision - Glass



Special glasses

Toughened glass may show visual distortions which are accentuated by reflections in double glazing. Such surface colourations and patterns do not indicate a change in physical performance. Laminated glass may have a few more blemishes due to it being made of several layers. Low emissivity coating may produce transient visual effects.

In some lighting conditions the coating may look like a transparent film or produce a haze, ie a cloudy look to the surface. When light coloured objects such as net curtains are placed close to the glazing they may look slightly darker.



See GGF Leaflets:

- Low Emissivity Glass and the conservation of fuel and power.
- Low Emissivity Glass conserve Scotland's fuel and power.
- Low Emissivity Glass for the Conservation of Northern Ireland's fuel and power.



Double reflection

This occurs in certain light conditions. It is caused by multiple surface reflections in double glazing which may vary from pane to pane.

Brewster's Fringes – the rainbow effect

Small transitory rainbow effects are sometimes produced by the glass refraction of light.

Their appearance is due to high quality flat glass sheets being placed parallel to each other.

Patterned glass

The above does not apply to patterned glass

Quality of Vision - Glass

Visual quality standard for installed insulating glass units constructed from flat transparent glass.

1. Transparent glass used in the manufacture of insulating glass units is identical to that used traditionally for single glass and will, therefore, have a similar level of quality.

2. Both panes of the sealed unit shall be viewed at right angles to the glass from the room side standing at a distance of no less than 2 metres but for toughened, laminated or coated glasses (not less than a distance of 3 metres) in natural daylight and not in direct sunlight with no visible moisture on the surface of the glass. The area to be viewed is the normal vision area with the exception of a 50mm wide band around the perimeter of the unit.

3. Flat transparent glass, including laminated or toughened (tempered) glass, shall be deemed acceptable if the following phenomena are neither obtrusive nor bunched: totally enclosed seeds, bubbles or blisters: hairlines or blobs; fine scratches not more than 25mm long, minute embedded particles. Obtrusiveness of blemishes shall be judged by looking through the glass, not at it, under lighting conditions as described in 2.

4. When thermally toughened glass is viewed by reflection, the effect of the toughening process may be seen under certain lighting conditions. The visibility of surface colouration or patterns does not indicate deterioration in the physical performance of the toughened glass.

5. Because of the nature of the toughening process, distortion will be accentuated when the glass is viewed in reflection or incorporated in insulating glass units.



Quality of Vision - Glass

6. Visible double reflection can occur under certain lighting aspect conditions, especially when viewed from an angle. This is an optical phenomenon arising from multiple surface reflections in sealed units.

7. The manufacture of flat laminated glass does not usually affect the visual quality of the glass incorporated in insulation glass units. However, the faults generally accepted in paragraph 3 may be increased in number if several glasses and interlayers are used in the production of laminated glass. When viewed under certain light conditions, insulating glass units incorporating clear or tinted flat laminated glass may show a distortion effect caused by a reflection on the multiple surfaces of the components of the laminated glass.

8. Brewster's Fringes
The appearance of the optical phenomenon known as Brewster's Fringes is not a defect of the glass, and can occur with any glass of high optical and surface quality. This phenomenon achieved world wide by modern methods of glass manufacture. Brewster's Fringes occur if wavelengths of light meet up with each other when they are exactly 180 degrees out of phase - an example of the phenomenon known to physicists as to the interference of light. The effect is similar to, although usually much smaller than, the interference fringes which can be seen on toughened glass windscreens. Brewster's Fringes occur when the surfaces of the glass are flat and the two panes of glass are parallel to each other, i.e. when the light transmission properties of the installation

are of a very high order. This phenomenon is not a defect of the product, being dependant on the laws of physics and not on the quality of the insulation glass. In fact it arises because modern glass made by the float process is flat, therefore, free of the distortion inherent in sheet glass. The occurrence of Brewster's Fringe is in its nature rather like (though very much more rare than) the fact that under certain conditions, the observer will see a reflection of himself in any window or door - and no-one could claim that this was a defect of the glass.

Note: Patterned Glass

The above criteria do not apply to patterned glass, as due to the method of manufacture, imperfections such as seeds and bubbles are deemed to be acceptable.



Protection of Windows

Protection of Windows & Glass

If any building or renovation works are taking place, do not remove the blue protective film that covers the glass and Georgian bars.

This will ensure that building related materials like sand, cement and paint cannot damage the surfaces.

If carrying out any decorating or building works in the future, please ensure the above mentioned protective film is re-applied to prevent any damage.

(Please contact your Installer for further information)

